

● TECHNICAL SPECIFICATIONS

- Channel: AIS 1 (CH2087), AIS 2 (CH2088)
- Frequency Error: ≤ 0.5 kHz
- Power: 1 W
- AIS Message Type: MSG 1 (MMSI, GNSS position, COG, SOG, UTC)
MSG 14 (MOB ACTIVE or MOB TEST)
- Range: 4 nm typical
- Operating Time: ≥ 48 hours
- Activation Method: Manual or water sensor automatic activation
- Positioning accuracy: ≤ 5 m (built-in GNSS positioning)

● BATTERY REQUIREMENTS

- Battery Voltage: DC 6 V
- Capacity: 1500 mAh
- Storage Temperature: $-30^{\circ}\text{C} \sim +70^{\circ}\text{C}$
- Storage (Battery Life): 5 years

● ENVIRONMENTAL CONDITIONS

- Operating Temperature: $-20^{\circ}\text{C} \sim +55^{\circ}\text{C}$
- IP Grade: IP67

● SIZE & WEIGHT

- Size: 127 (H) \times 49.2 (W) \times 33.7 (D) mm
- Weight: 180 g

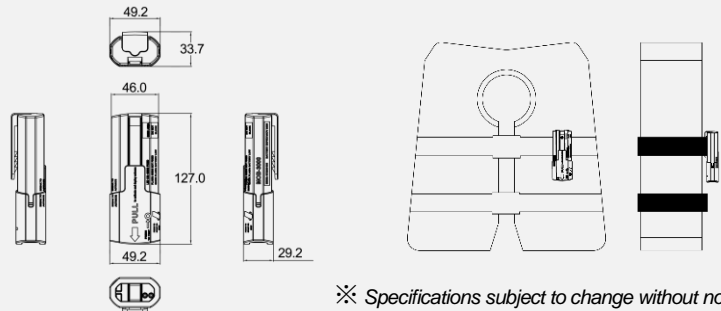

※ Specifications subject to change without notice

- Designed to locate the overboard crew and help for rescue operation.
- Conforms to the latest standards including IEC 61097-14, IEC 60945, ITU-R M.1371-5, IEC 61108-1.
- Adopts Automatic Identification System (AIS) technology to transmit the position reports on VHF band continuously. The transmission can be quickly received by the AIS device installed on mother ship and surrounding ships or approaching helicopter.
- The GNSS in the device makes the accuracy of the position within 5m, which can facilitate to locate the target in the sea easily.
- Two operation modes, manual activation and automatic activation by water sensor.
- Test mode available for daily test with test pin.
- Can operate continuously for at least 48 hours.
- Can be fixed on a life jacket.

